









Silicon Carbide for Medical

SemiQ provides high efficiency Silicon Carbide (SiC) components, including diodes, modules, and MOSFETs, for use in the medical industry. These products enable cutting-edge technologies that require high precision and efficiency. Medical devices, such as MRI systems, are complex medical imaging devices that use strong magnetic fields and radio waves to generate detailed images of the internal structures of the human body.

These systems are primarily powered by specialized power electronics, which are carefully designed to avoid electromagnetic interference (EMI) that could disrupt the MRI's sensitive imaging process.

SemiQ SiC MOSFETs offer advantages in various power electronics applications for medical devices, including high efficiency, high switching frequencies, and high-temperature operation.

Benefits of SemiQ QSiC™ in Medical Applications

 High Efficiency	 Reliable Performance	 Precision and Accuracy	 Wide Range Of Options
 Heat Management	 Compact and Lightweight	 High-Temperature Tolerance	 Advanced Technology

Typical Medical Schematic

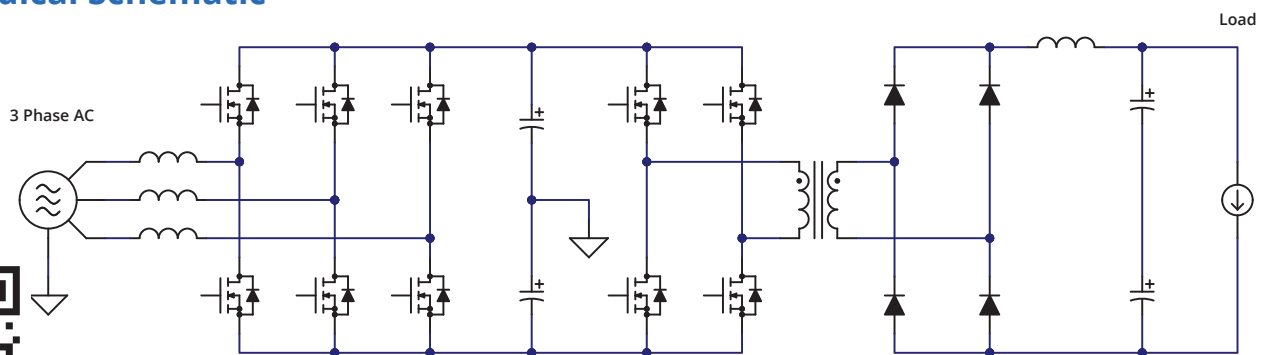

Silicon Carbide for Medical

Silicon Carbide (SiC) semiconductors offer significant advantages in the medical industry. With their high thermal conductivity and robustness, SiC devices enable efficient power management and control in medical equipment such as MRI machines, ultrasound systems, and X-ray devices. The material's ability to withstand high temperatures and harsh operating conditions ensures reliability and longevity, critical for sensitive medical procedures. Additionally, SiC's low power loss characteristics contribute to energy efficiency, reducing operational costs and environmental impact. These properties make SiC semiconductors invaluable for enhancing performance and safety in various medical applications.

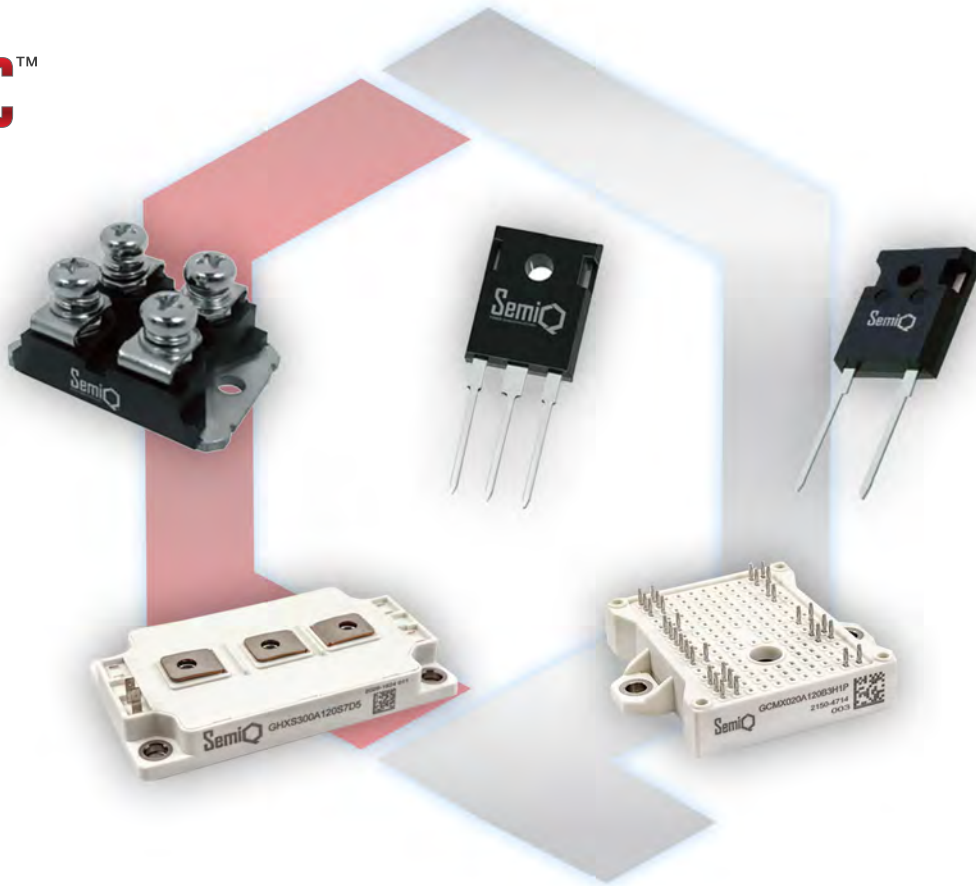

SemiQ specializes in providing high-quality, efficient standard, and custom Silicon Carbide (SiC) Power Semiconductors for high-voltage applications. Our product portfolio includes MOSFETs and diodes, available in discrete, module and bare die that combine high-performance with industry-leading reliability.