

SPECIFICATIONS

Customer	
Product Name	Polymer Tantalum Chip Capacitors
Sunlord Part Number	TC311 Series
Customer Part Number	

New Released, Revised]

SPEC: **TC050220000**

【This SPEC is total 12 pages including specifications and appendix.】

【ROHS, Halogen-Free and SVHC Compliant Parts】

Approved By	Checked By	Issued By

Shenzhen Sunlord Electronics Co., Ltd.

Address: Sunlord Industrial Park, Dafuyuan Industrial Zone, Guanlan, Shenzhen, China 518110

Tel: 0086-755-29832333

Fax: 0086-755-82269029

E-Mail: sunlord@sunlordinc.com

【For Customer approval Only】

Date: _____

Qualification Status: Full Restricted Rejected

Approved By	Verified By	Re-checked By	Checked By

Comments:

【Version change history】

Rev.	Effective Date	Changed Contents	Change reasons	Approved By
01	/	New release	/	Hai Guo

Caution:

All products listed in this specification are developed, designed and intended for use in general electronics equipment. The products are not designed or warranted to meet the requirements of the applications listed below, whose performance and/or quality require especially high reliability, or whose failure, malfunction or trouble might directly cause damage to society, person, or property. Please understand that we are not responsible for any damage or liability caused by use of the products in any of the applications below. Please contact us for more details if you intend to use our products in the following applications.

1. Aircraft equipment
2. Aerospace equipment
3. Undersea equipment
4. nuclear control equipment
5. military equipment
6. Power plant equipment
7. Medical equipment
8. Transportation equipment (automobiles, trains, ships,etc.)
9. Traffic signal equipment
10. Disaster prevention / crime prevention equipment
11. Data-processing equipment
12. Applications of similar complexity or with reliability requirements comparable to the applications listed in the above

1. Scope

This specification applies to TC311 series of Polymer Tantalum Chip Capacitors.

2. Reference

EIA Standard 535BAAC—A Fixed Tantalum Chip Capacitor Style 1 Protected(molded)

GJB 360A—96 Test methods for electronic and electrical component parts

IEC384-3-1 Test Methods for Environmental Testing

MIL-STD-202 DEPARTMENT OF DEFENSE TEST METHOD STANDARD ELECTRONIC AND ELECTRICAL COMPONENT PARTS

3. Product Description and Identification (Part Number)

1) Description

TC311 series of Polymer Solid Tantalum Chip Capacitors.

2) Product Identification (Part Number)

TC **311** **B** **107** **M** **004** **B** **150**
 ① ② ③ ④ ⑤ ⑥ ⑦ ⑧

①

Type	
TC	Solid Tantalum Chip Capacitor

②

Series	
311	Polymer

③

External Dimensions (LxW) (mm)	
B	3.5x2.8
C	6.0x3.2
D	7.3x4.3
E	7.3x4.3
W	7.3x6.0
G2	8.5x7.5

④

Nominal Capacitance	
Example	Nominal Value
105	1.0μF
107	100μF

⑤

Capacitance Tolerance	
K	±10%
M	±20%

⑥

Rated DC Voltage	
002	2.5Vdc
004	4Vdc
006	6.3Vdc
010	10Vdc
016	16Vdc

⑦

Internal Code	
B	Black Molded Case, Laser marking
Y	Yellow Molded Case, Laser marking

⑧

ESR	
070	70mΩ
100	100mΩ

3) Markings

Rated Voltage Code

Rated Voltage (V)	2.5	4	6.3	10	16
Code	2V	4V	6V	10V	16V

Capacitance Code

Capacitance (μF)	10	22	33	47	68	100	150	220	330	470	680	1000	3300
Code (B/C/D/E/M/G2 Case)	106	226	336	476	686	107	157	227	337	477	687	108	338

Markings

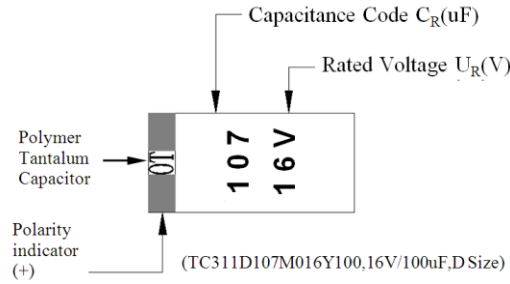

C/B/D/V/E/W/G2 Case Marking

4. Electrical Characteristics

TC311 Series

Capacitance (μF)	Case	Part Number	DCL (μA) +25°C Max.	DF (%) +25°C 120Hz Max.	ESR (m Ω) +25°C 100kHz Max.
2.5V, +85°C (2.0V @ +105°C)					
680	E	TC311E687 \odot 002 \square 070	170	12	70
1000	E	TC311E108 \odot 002 \square 070	250	12	70
3300	G2	TC311G2338 \odot 002 \square 070	825	12	70
4V, +85°C (3.2V @ +105°C)					
10	B	TC311B106 \odot 004 \square 150	4	10	150
15	B	TC311B156 \odot 004 \square 150	6	10	150
22	B	TC311B226 \odot 004 \square 150	8.8	10	150
22	C	TC311C226 \odot 004 \square 150	8.8	10	150
33	B	TC311B336 \odot 004 \square 150	13.2	10	150
33	C	TC311C336 \odot 004 \square 150	13.2	10	150
33	D	TC311D336 \odot 004 \square 150	13.2	10	150
33	D	TC311D336 \odot 004 \square 200	13.2	10	200
47	B	TC311B476 \odot 004 \square 200	18.8	10	200
47	C	TC311C476 \odot 004 \square 150	18.8	10	150
47	D	TC311D476 \odot 004 \square 150	18.8	10	150
68	B	TC311B686 \odot 004 \square 150	27.2	10	150
68	C	TC311C686 \odot 004 \square 150	27.2	10	150
68	D	TC311D686 \odot 004 \square 150	27.2	10	150
100	B	TC311B107 \odot 004 \square 150	40	10	150
100	C	TC311C107 \odot 004 \square 150	40	10	150
100	D	TC311D107 \odot 004 \square 100	40	10	100
150	D	TC311D157 \odot 004 \square 100	60	12	100
150	E	TC311E157 \odot 004 \square 100	60	12	100
220	D	TC311D227 \odot 004 \square 100	88	12	100
220	E	TC311E227 \odot 004 \square 100	88	12	100
330	D	TC311D337 \odot 004 \square 100	132	12	100
330	E	TC311E337 \odot 004 \square 090	132	12	90
470	D	TC311D477 \odot 004 \square 100	188	12	100
470	E	TC311E477 \odot 004 \square 090	188	12	90
680	E	TC311E687 \odot 004 \square 090	272	12	90

Capacitance (μF)	Case	Part Number	DCL (μA) +25°C Max.	DF (%) +25°C 120Hz Max.	ESR (m Ω) +25°C 100kHz Max.
6.3V, +85°C (5.0V @ +105°C)					
10	B	TC311B106 \odot 006 \square 350	6.3	10	350
15	B	TC311B156 \odot 006 \square 350	9.45	10	350
22	B	TC311B226 \odot 006 \square 200	13.86	10	200
22	C	TC311C226 \odot 006 \square 200	13.86	10	200
33	B	TC311B336 \odot 006 \square 200	20.79	10	200
33	C	TC311C336 \odot 006 \square 150	20.79	10	150
33	D	TC311D336 \odot 006 \square 150	20.79	10	150
47	B	TC311B476 \odot 006 \square 150	29.61	10	150
47	C	TC311C476 \odot 006 \square 150	29.61	10	150
47	D	TC311D476 \odot 006 \square 150	29.61	10	150
68	B	TC311B686 \odot 006 \square 150	42.84	10	150
68	C	TC311C686 \odot 006 \square 150	42.84	10	150
68	D	TC311D686 \odot 006 \square 150	42.84	10	150
100	B	TC311B107 \odot 006 \square 150	63	10	150
100	C	TC311C107 \odot 006 \square 150	63	10	150
100	D	TC311D107 \odot 006 \square 150	63	10	150
150	D	TC311D157 \odot 006 \square 100	94.5	12	100
150	E	TC311E157 \odot 006 \square 090	94.5	12	90
220	D	TC311D227 \odot 006 \square 090	138.6	12	90
220	E	TC311E227 \odot 006 \square 090	138.6	12	90
330	D	TC311D337 \odot 006 \square 090	207.9	12	90
330	E	TC311E337 \odot 006 \square 090	207.9	12	90
470	D	TC311D477 \odot 006 \square 090	296.1	12	90
470	E	TC311E477 \odot 006 \square 090	296.1	12	90
680	E	TC311E687 \odot 006 \square 090	428.4	12	90
1000	E	TC311E108 \odot 006 \square 090	630	12	90
10V, +85°C (8.0V @ +105°C)					
10	B	TC311B106 \odot 010 \square 150	10	10	150
15	B	TC311B156 \odot 010 \square 150	15	10	150

TC311 Series

Capacitance (μF)	Case	Part Number	DCL (μA) +25°C Max.	DF (%) +25°C 120Hz Max.	ESR (mΩ) +25°C 100kHz Max.
10V, +85°C (8.0V @ +105°C)					
15	C	TC311C156◎010□150	15	10	150
22	B	TC311B226◎010□150	22	10	150
22	C	TC311C226◎010□150	22	10	150
33	B	TC311B336◎010□150	33	10	150
33	C	TC311C336◎010□150	33	10	150
33	D	TC311D336◎010□150	33	10	150
47	B	TC311B476◎010□150	47	10	150
47	C	TC311C476◎010□150	47	10	150
47	D	TC311D476◎010□150	47	10	150
68	B	TC311B686◎010□150	68	10	150
68	C	TC311C686◎010□150	68	10	150
68	D	TC311D686◎010□150	68	10	150
100	C	TC311C107◎010□150	100	10	150
100	D	TC311D107◎010□150	100	10	150
100	E	TC311E107◎010□150	100	10	150
150	D	TC311D157◎010□100	150	12	100
150	E	TC311E157◎010□090	150	12	90
220	D	TC311D227◎010□100	220	12	100
220	E	TC311E227◎010□090	220	12	90
330	D	TC311D337◎010□100	330	12	100
330	E	TC311E337◎010□090	330	12	90
470	E	TC311E477◎010□090	470	12	90

Capacitance (μF)	Case	Part Number	DCL (μA) +25°C Max.	DF (%) +25°C 120Hz Max.	ESR (mΩ) +25°C 100kHz Max.
16V, +85°C (12.8V @ +105°C)					
10	B	TC311B106◎016□150	16	10	150
10	C	TC311C106◎016□150	16	10	150
10	D	TC311D106◎016□150	16	10	150
15	B	TC311B156◎016□150	24	10	150
15	C	TC311C156◎016□150	24	10	150
22	B	TC311B226◎016□150	35.2	10	150
22	C	TC311C226◎016□150	35.2	10	150
33	B	TC311B336◎016□150	52.8	10	150
33	C	TC311C336◎016□150	52.8	10	150
33	D	TC311D336◎016□150	52.8	10	150
47	C	TC311C476◎016□150	75.2	10	150
47	D	TC311D476◎016□150	75.2	10	150
68	C	TC311C686◎016□150	108.8	10	150
68	D	TC311D686◎016□150	108.8	10	150
100	D	TC311D107◎016□100	160	10	100
100	E	TC311E107◎016□090	160	10	90
150	D	TC311D157◎016□100	240	12	100
150	E	TC311E157◎016□090	240	12	90
220	E	TC311E227◎016□090	352	12	90
330	E	TC311E337◎016□090	528	12	90
330	W	TC311W337◎016□070	528	12	70
470	W	TC311W477◎016□070	752	12	70

◎ Please: specify the capacitance tolerance code (K=±10%, M=±20%)

□ Please: specify the internal code (B=Black molded case, Y=Yellow molded case)

5. Shape and Dimensions

- 1) Dimensions and recommended PCB pattern for reflow soldering: See Fig.5-1, Fig.5-2 and Table 5-1
- 2) Structure: See Fig. 5-3

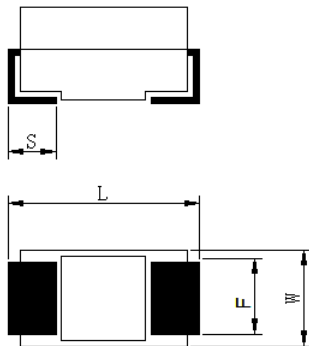

Fig. 5-1

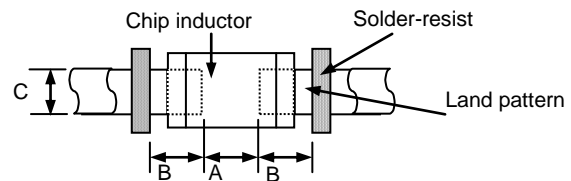

Fig. 5-2

Tab.5-1

Unit: mm [inch]

单位: mm [inch]

Case Code	Type	L	W	H	F(± 0.10) [± 0.04]	S(± 0.30) [± 0.12]	A	B	C
B	3528-21	3.5 \pm 0.2 [.134 \pm .008]	2.8 \pm 0.2 [.11 \pm .008]	1.9 \pm 0.2 [.075 \pm .008]	2.2 [.087]	0.8 [.031]	1.4	1.35	2.7
C	6032-28	6.0 \pm 0.30 [.236 \pm .012]	3.2 \pm 0.30 [.126 \pm .012]	2.5 \pm 0.30 [.098 \pm .012]	2.2 [.087]	1.3 [.051]	2.9	2.0	2.7
D	7343-31	7.3 \pm 0.30 [.287 \pm .012]	4.3 \pm 0.30 [.169 \pm .012]	2.8 \pm 0.30 [.110 \pm .012]	2.4 [.094]	1.3 [.051]	4.1	2.05	2.9
E	7343-43	7.3 \pm 0.30 [.287 \pm .012]	4.3 \pm 0.30 [.169 \pm .012]	4.0 \pm 0.3 [.157 \pm .012]	2.4 [.094]	1.3 [.051]	4.1	2.05	2.9
W	7360-41	7.30 \pm 0.30 [.287 \pm .012]	6.00 \pm 0.30 [.236 \pm .012]	4.10 \pm 0.30 [.161 \pm .012]	3.00 \pm 0.10 [.118 \pm .004]	1.50 \pm 0.30 [.059 \pm .012]	4.1	2.05	3.5
G2	8575-65	8.50 \pm 0.30 [.334 \pm .012]	7.50 \pm 0.30 [.295 \pm .012]	6.50 \pm 0.30 [.256 \pm .012]	4.50 \pm 0.30 [.177 \pm .012]	1.50 \pm 0.30 [.059 \pm .012]	5.3	2.05	5.0

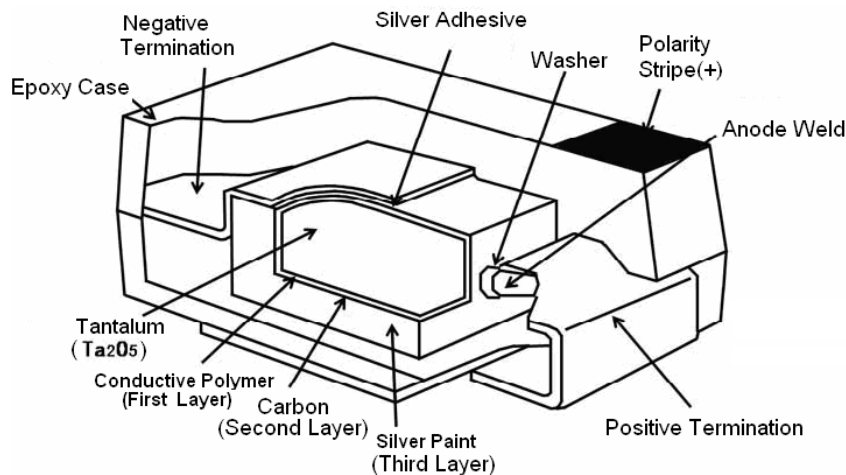

Fig. 5-3

6. Test and Measurement Procedures

6.1 Test Conditions

Unless other specified, the standard atmospheric conditions for measurement/test as:

- Ambient Temperature: 25 \pm 10 $^{\circ}$ C
- Relative Humidity: 50 \pm 30%RH
- Air Pressure: 86KPa ~106KPa

If any doubt on the results, measurements/tests should be made within the following limits:

- Ambient Temperature: 25 \pm 1 $^{\circ}$ C
- Relative Humidity: 50 \pm 2%RH
- Air Pressure: 86KPa ~ 106KPa

6.2 Visual Examination

Inspection Equipment: 20X magnifier

6.3 Electrical Test

6.3.1 Equivalent Series Resistance (ESR)

- Test frequency: 100 \pm 5KHz, Refer to **Appendix A**
- Test equipment (Analyzer): HP4263B or equal ESR Tester

6.3.2 Capacitance (C)

- Test frequency :120 \pm 5Hz, Refer to **Appendix A**
- Test equipment: HP4263B or equal capacitance tester
- Test signal: 1000mV

6.3.3 Dissipation Factor (tan δ)

- Test frequency: 120 \pm 5Hz, Refer to **Appendix A**
- Test equipment: HP4263B or equal capacitance tester
- Test signal: 1000mV

6.3.4 Leakage Current (I_0)

- Refer to **Appendix A**

- b. Test equipment: TH2686 or equivalent I_0 test equipment.
- c. Measurement method:
 1. The chip shall be charged for 5min at most at rated voltage at 25°C.
 2. Current decreases as time passes, but gets into a stable situation at a certain value which shall be recorded as I_0 .

6.3.5 Rated Voltage (U_R)

Rated voltage is the maximum DC operating voltage for continuous duty at -55°C~85°C. Capacitor may be operated at 105°C with voltage derating to 80% of rated voltage. The derated voltages at different operating temperatures are listed in the table below. Refer to the table below for detail data.

Rated Voltage (U_R)	2.5V	4V	6.3V	10V	16	@-55°C~85°C
Derated voltage (U_c)	2.0V	3.2V	5.0V	8.0V	10V	@105°C

6.4 Reliability Test

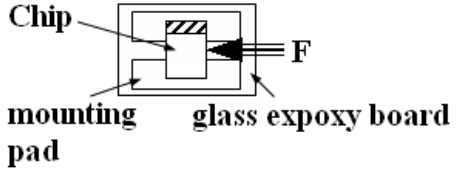
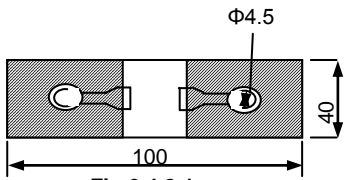
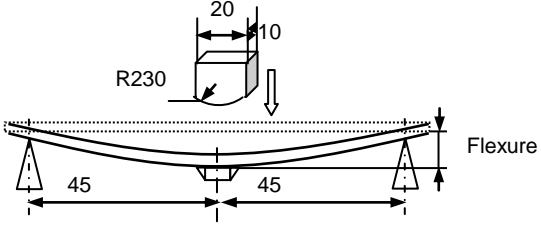
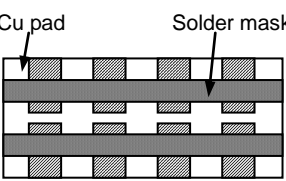
Item	Requirements	Test Methods and Remarks																		
6.4.1 Terminal Strength	1、shear  Fig.6.4.1-1	1、shear ① Solder the capacitor to the test board(glass epoxy board shown in Fig. 6.4.1-1) , then apply a force in the direction as Fig. 6.4.1-1; ② Case code and shear: <table border="1" data-bbox="782 846 1380 1079"> <thead> <tr> <th>Case code</th> <th>Size</th> <th>Max. Shear (Kg)</th> </tr> </thead> <tbody> <tr> <td>B</td> <td>3528-21</td> <td>3.6</td> </tr> <tr> <td>D</td> <td>7343-31</td> <td>5.0</td> </tr> <tr> <td>E</td> <td>7343-43</td> <td>5.0</td> </tr> <tr> <td>W</td> <td>7360-41</td> <td>5.0</td> </tr> <tr> <td>G2</td> <td>8575-65</td> <td>5.0</td> </tr> </tbody> </table> ③ Keep time: 10±1sec; ④ speed: 1.0mm/sec.	Case code	Size	Max. Shear (Kg)	B	3528-21	3.6	D	7343-31	5.0	E	7343-43	5.0	W	7360-41	5.0	G2	8575-65	5.0
Case code	Size	Max. Shear (Kg)																		
B	3528-21	3.6																		
D	7343-31	5.0																		
E	7343-43	5.0																		
W	7360-41	5.0																		
G2	8575-65	5.0																		
6.4.2 Resistance to Flexure	No visible mechanical damage. unit: mm  Fig.6.4.2-1	① Solder the capacitor to the test jig (glass epoxy board shown in Tab. 5-1) Using a eutectic solder. Then apply a force in the direction shown in Fig. 6.4.2-1~Fig. 6.4.2-2 ② Flexure:1 mm; ③ Pressurizing Speed: 0.5mm/sec. ④ Keep time: 10 sec.  Fig.6.4.2-2																		
6.4.3 Vibration	No visible mechanical damage.  Glass Epoxy Board Fig.6.4.3-1	① Solder the capacitor to the testing jig (glass epoxy board shown in Fig.6.4.3-1) using eutectic solder. ② The capacitor shall be subjected to a simple harmonic motion having total amplitude of 1.5mm, the frequency being varied uniformly between the approximate limits of 10 and 55 Hz. ③ The frequency range from 10 to 55 Hz and return to 10 Hz shall be traversed in approximately 1 minute. This motion shall be applied for a period of 2 hours in each 3mutually perpendicular directions (total of 6 hours).																		

<p>6.4.4 Solderability</p>	<p>① No visible mechanical damage. ② Wetting shall exceed 95% coverage. ③ The less 5% of area is permitted to contain a few defect , such as pinholes、holes、un-soaking or poor soaking area which do not gather together.</p>	<p>① Solder temperature: 235±2℃ ② Duration: 3 sec. ③ Solder: Sn/3.0Ag/0.5Cu ④ Flux: 25% Resin and 75% ethanol in weight.</p>
<p>6.4.5 Resistance to Soldering Heat</p>	<p>① No visible mechanical damage. ② Wetting shall exceed 95% coverage. ③ Capacitance change: within ±10%. ④ tanδ shall not exceed 150% of the initial requirement. ⑤ Leakage current change shall not exceed the initial I₀.</p>	<p>① Solder temperature: 260±3℃ ② Duration: 5 sec. ③ Solder: Sn/3.0Ag/0.5Cu ④ Flux: 25% Resin and 75% ethanol in weight. ⑤ The chip shall be stabilized at normal condition for 2 hours before measuring.</p>

<p>6.4.6 Temperature properties</p>	<p>A. At -55℃ ① No visible mechanical damage. ② Capacitance change: within±20%. ③ tanδ shall not exceed the initial requirement.</p>	<p>① Drying 30⁺⁴ min at 105℃ ② The chip shall be stabilized at normal condition for 2 hours after drying, and measured at 25℃ as initial data. ③ The chip shall be measured at -55℃.</p>
	<p>B. At 25℃ ① No visible mechanical damage. ② Capacitance change: within ±10% ③ tanδ shall not exceed the initial requirement. ④ Leakage current shall not exceed I₀.</p>	<p>① After Step A, the chip shall be cooled to 25℃ and measured.</p>
	<p>C. C. At 85℃ ① No visible mechanical damage. ② Capacitance change: within ±20% ③ tanδ shall not exceed 120% of the initial requirement. ④ Leakage current shall not exceed 10 I₀.</p>	<p>① After Step B, the chip shall be measured at 85℃.</p>
	<p>D. At 105℃ ① No visible mechanical damage. ② Capacitance change: within ±30%. ③ tanδ shall not exceed 150% of the initial requirement. ④ Leakage current shall not exceed 10 I₀.</p>	<p>① After Step C, the chip shall be measured at 105℃.</p>
	<p>E. At 25℃ ① No visible mechanical damage. ② Capacitance change: within ±10% ③ tanδ shall not exceed the initial requirement. ④ Leakage current shall not exceed I₀.</p>	<p>① After Step D, the chip shall be cooled to 25℃ and measured.</p>

<p>6.4.7 Thermal Shock</p>	<p>① Capacitance change: within -20%~+10%. ② tanδ shall not exceed the initial requirement. ③ Leakage current shall not exceed the initial I₀. ④ ESR shall not exceed 200% of the initial requirement.</p>	<p>① Temperature, Time (See Fig.6.4.7) ② -55℃, 30±3 min→105℃, 30±3min. ③ Transforming interval: Max.5min. ④ Tested cycle: 500cycles. ⑤ The chip shall be stabilized at normal condition for 2 hours before measuring.</p> <div data-bbox="877 1702 1356 1926" style="text-align: center;"> </div> <p style="text-align: center;">Fig.6.4.7</p>
--------------------------------	---	---

<p>6.4.8 Moisture Resistance</p>	<p>① No visible mechanical damage. ② Capacitance change: -5%~+35%. ③ $\tan\delta$ shall not exceed of the initial requirement. ④ Leakage current shall not exceed $5I_0$. ⑤ ESR shall not exceed 200% of the initial requirement.</p>	<p>① Temperature: $60\pm 2^\circ\text{C}$. ② Relative Humidity: 90%~95%RH. ③ Duration: 500^{+24} hours. ④ The chip shall be stabilized at normal condition for 2 hours before measuring.</p>
<p>6.4.9 Life Test</p>	<p>① No visible mechanical damage. ② Capacitance change: -20%~+10%. ③ $\tan\delta$ shall not exceed the initial requirement. ④ Leakage current shall not exceed I_0. ⑤ ESR shall not exceed the initial requirement.</p>	<p>① Temperature: $85\pm 2^\circ\text{C}$; Rated Voltage ② Duration: 2000^{+24} hours ③ The chip shall be stabilized at normal condition for 2 hours before measuring.</p>

7. Packaging, Storage and Transportation

7.1 Packaging

7.1.1 Tape Carrier Packaging:

Refer to Fig.7.1-1~3 for detail. Tape carrier packaging quantity is listed in the following table:

Case code	EIA size	Package quantity
B	3528	2000
D	7343	500
E	7343	500
W	7360	400
G2	8575	400

(1) Taping Drawings (Unit: mm)

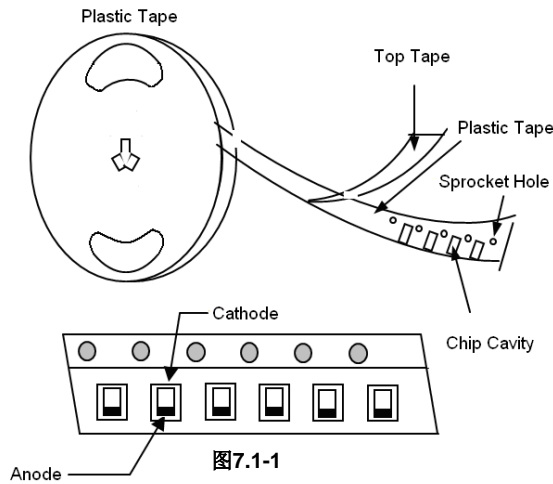

Note: The sprocket holes are to the right as the tape is pulled toward the user.

(2) Taping Dimensions (Unit: mm)

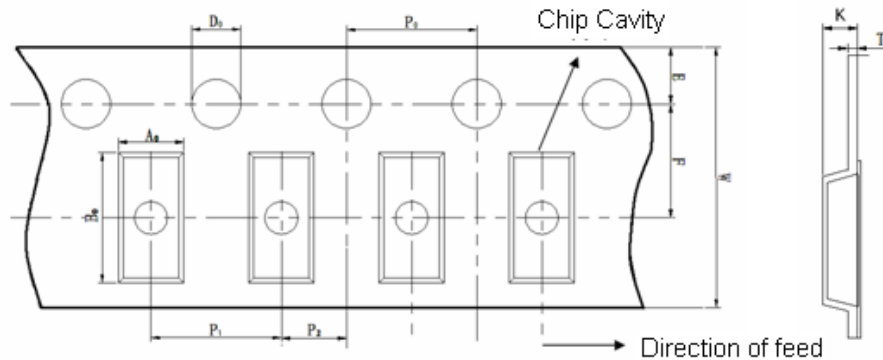

Fig7.1-2

Case	W	A ₀	B ₀	P ₀	F	K max	T max
B	8.0±0.3	3.10±0.20	3.80±0.20	4.0±0.1	3.5±0.05	2.3	0.3
D	12.0±0.3	4.60±0.20	7.60±0.20	8.0±0.1	5.5±0.05	3.3	0.3
V	12.0±0.3	4.60±0.20	7.60±0.20	8.0±0.1	5.5±0.05	2.4	0.3
E	12.0±0.3	4.60±0.20	7.60±0.20	8.0±0.1	5.5±0.05	4.3	0.3
W	16.0±0.3	6.60±0.10	8.00±0.10	12.0±0.1	7.5±0.1	4.6	0.4

(3) Reel Dimensions (Unit: mm)

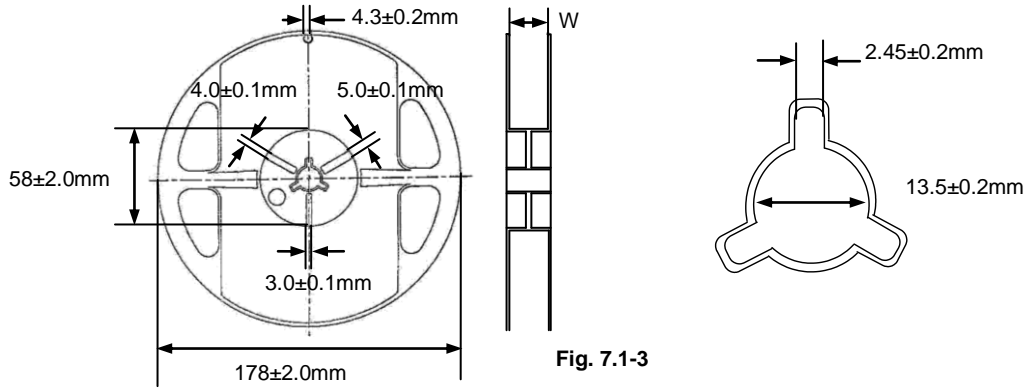

Fig. 7.1-3

Case code	Tape width	W
B	8mm	10mm
C、D、E	12mm	13mm

Storage

The solderability of the external electrode may be deteriorated if packages are stored where they are exposed to high humidity. Package must be stored at 40°C or less and 70% RH or less;

The solderability of the external electrode may be deteriorated if packages are stored where they are exposed to dust of harmful gas (e.g. HCl, sulfurous gas of H₂S);

Packaging material may be deformed if package are stored where they are exposed to heat of direct sunlight;

The minimum package and polyethylene package should not be opened until the capacitors are used; once they were opened, use the capacitors as soon as possible.

Solderability specified shall be guaranteed for 12 months from the date of delivery on condition that they are stored at the environment specified in **Clause 4**. For those parts, which passed more than 12 months shall be checked solder-ability before use

7.3 Transportation

Package should not be destroyed or get wet.

7.4 Precautionary measures

- a. Put on electrostatic prevention to avoid ESD.
- b. Equipments involved in capacitor application (such as soldering tip and tester) should be well grounded.
- c. Avoid touching electrode directly by hand or metal (such as metal table).

7.5 Cautions for Using Tantalum Capacitor

The ratio of operating voltage to rated voltage has a great influence on capacitor failures. Please take all specified reliabilities into account and derate operating voltage appropriately when a practical circuit is designed.

- a. The operating voltage of tantalum capacitors used in low impedance circuits, such as filters for power supplies (particularly switching power supplies), should be derated to less than **54%** of rated voltage. In other case, keep the operating voltage below **80%** of rated voltage. Refer to **Fig.7.5-1** for detail:

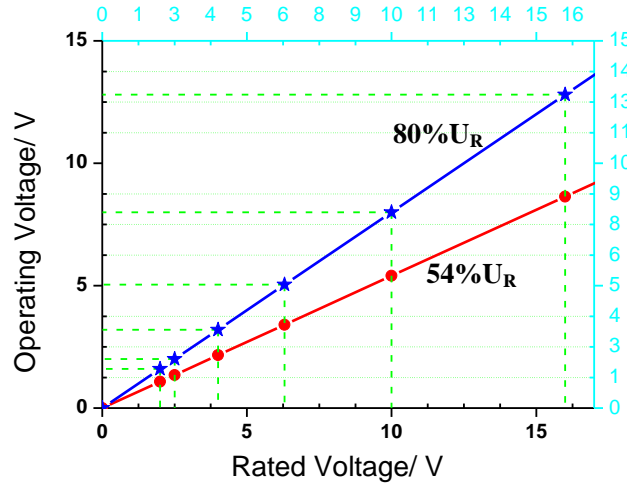

Fig7.5-1

- b. In low impedance circuits, connecting capacitors in parallel will increase the risk of the failure caused by DC surge current. Please pay attention to the electric charge in capacitor with parallel connection which can be discharged by other capacitors.
- c. Connecting a resistor in series with capacitor is suggested to alleviate the shock caused by excessive momentary current. Please connect a protecting resistor of 3Ω/V or higher in series with the capacitor to keep current below 300mA. If protecting resistors could not be applied; please make sure operating voltage is below 54% of rated voltage (Fig.7.5-1).

7.5.2 Reverse voltage

Since tantalum capacitor has polarity, do not apply a reverse voltage to it. Do not apply capacitor to a circuit which only has alternating current.

- a. If there is no alternation, applying a low reverse voltage which is listed below to capacitor in a short time is approved:

Tab.2

Temp.	Max. Reverse voltage in a short time
25°C	15%UR (rated voltage)
55°C	10% UR (rated voltage)
85°C	5% UR (rated voltage)
105°C	3% UR (rated voltage)

- b. In principle, testing a circuit with tantalum capacitor or capacitor itself by using a resistor gear of millimeters in ignorance of polarity is forbidden.
- c. During measurement and application, if the tantalum capacitor is subjected to an undesirable reverse voltage due to carelessness, please dispose it, even if its electrical characteristics are still qualified.

7.5.3 Ripple voltage

Please use the capacitor within permissible ripple voltage.

- a. The sum of DC bias voltage and the maximum AC branch voltage should not exceed rated voltage during operation.
- b. The sum of negative peak AC value and DC bias voltage should not exceed the specified reverse voltage.
- c. Ripple current applied to capacitor will generate active power loss, which will raise the rate of the failure caused by heat due to self-heat generation of capacitor. Therefore, ripple current and permissible power loss must be in control.

7.5.4 Mounting

In mounting, if the capacitor has underwent excessive mechanical and thermal shock which may cause deterioration of electrical characteristics, open circuits and short circuits, please confirm the practical mounting conditions before usage.

8. Recommended Soldering Technologies

8.1 Re-flowing Profile:

Process	Pb-Free Soldering
Preheat/Soak	
Min temp.(T_{smin})	150°C
Max temp.(T_{smax})	200°C
Time(t_s):from T_{smin} to T_{smax}	60~120 sec
Heating rate(T_L to T_p)	3°C/sec max
Liquidous temp.(T_L)	217 °C
Time above Liquidous (t_L)	60~150 sec
Peak temp.(T_p)	250°C* 260°C**
Time within 5°C of max peak temp.(t_p)	30sec max
Cooling rate (T_p to T_L)	6°C/sec max
Time from 25°C to peak temp.	8 min max

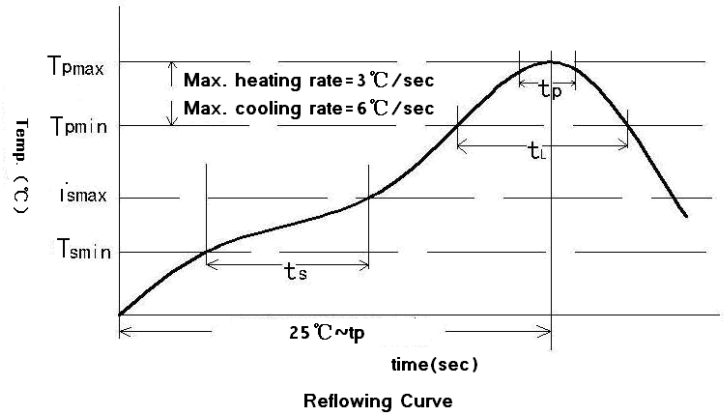

Note: 1、 *for D、 V 、 E Case.

2、 **for B Case.

3、 Max. 2 times for reflowing.

8.2 Iron Soldering Profile:

- △ Iron soldering power: Max.30W
- △ Pre-heating: 150 °C/60sec.
- △ Soldering Tip temperature: 350°C Max.
- △ Soldering time: 3sec. Max.
- △ Solder paste: Sn/3.0Ag/0.5Cu
- △ Max.1 times for iron soldering

[Note: Take care not to apply the tip of the soldering iron to the terminal electrodes.]

