

SPECIFICATIONS

Customer	
Product Name	Thin Film RF Inductor
Sunlord Part Number	HQ0402H-T01 Series
Customer Part Number	

New Released, Revised]

SPEC No.: **HQ0603200000**

【This SPEC is total 12 pages including specifications and appendix. 】

【ROHS, Halogen-Free and SVHC Compliant Parts】

Approved By	Checked By	Issued By

Shenzhen Sunlord Electronics Co., Ltd.

Address: Sunlord Industrial Park, Dafuyuan Industrial Zone, Baoan, Shenzhen, China 518110

Tel: 0086-755-29832333

Fax: 0086-755-82269029

E-Mail: sunlord@sunlordinc.com

【For Customer approval Only】

Date: _____

Qualification Status: Full Restricted Rejected

Approved By	Verified By	Re-checked By	Checked By

Comments:

【Version change history】

Rev.	Effective Date	Changed Contents	Change reasons	Approved By
01	/	New release	/	Xiangdong Zeng

Caution

All products listed in this specification are developed, designed and intended for use in general electronics equipment. The products are not designed or warranted to meet the requirements of the applications listed below, whose performance and/or quality require especially high reliability, or whose failure, malfunction or trouble might directly cause damage to society, person, or property. Please understand that we are not responsible for any damage or liability caused by use of the products in any of the applications below. Please contact us for more details if you intend to use our products in the following applications.

1. Aircraft equipment
2. Aerospace equipment
3. Undersea equipment
4. nuclear control equipment
5. military equipment
6. Power plant equipment
7. Medical equipment
8. Transportation equipment (automobiles, trains, ships, etc.)
9. Traffic signal equipment
10. Disaster prevention / crime prevention equipment
11. Data-processing equipment
12. Applications of similar complexity or with reliability requirements comparable to the applications listed in the above

Measuring Method of Inductance

- a. Residual elements and stray elements of test fixture can be described by F-parameter as shown in the following:

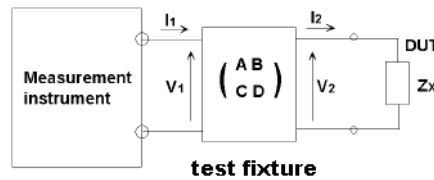

$$\begin{bmatrix} V_1 \\ I_1 \end{bmatrix} = \begin{bmatrix} A & B \\ C & D \end{bmatrix} \begin{bmatrix} V_2 \\ I_2 \end{bmatrix}$$

$$\begin{bmatrix} V_1 \\ I_1 \end{bmatrix} = \begin{bmatrix} AV_2 + BI_2 \\ CV_2 + DI_2 \end{bmatrix}$$

- Measured open impedance: $Z_{om} = \frac{A}{B}$
 Measured short impedance: $Z_{sm} = \frac{A}{C} \approx -Z_{sc}$ (when uses short chip to short)
 Measured short ship impedance: Z_{sD}
 Measured value: $Z_{xm} = V_1 / I_1$
 Impedance of DUT: $Z_x = V_2 / I_2$

- b. The relation between Z_x and Z_{om} , Z_{sm} , Z_{xm} is shown in the following:

$$Z_x = \frac{V_2}{I_2} = \frac{D}{A} * \frac{\frac{V_1}{I_1} - \frac{B}{D}}{1 - \frac{V_1}{I_1} * \frac{C}{A}} = \frac{D}{A} * \frac{Z_{xm} - \frac{B}{D}}{1 - Z_{xm} * \frac{C}{A}} = \frac{D}{A} * \frac{Z_{xm} - Z_{sm}}{1 - Z_{xm} / Z_{om}}$$

- c. L_x should be calculated with the following equation:

$$L_x = \frac{\ln(Z_x)}{2\pi f} = \frac{\ln(Z_{xm} + Z_{sc})}{2\pi f} = \frac{\ln(Z_{xm})}{2\pi f} + \frac{\ln(Z_{sc})}{2\pi f} = L_{xm} + L_{sc}$$

- L_{xm} : Measured chip inductor inductance
 L_{sc} : Measured short chip inductance
 L_x : Nominal Inductance of chip inductor

Compensation Value (Lsc) of Short Chip

Series	Compensation Value
HQ0402H-T01	0.11nH

1. Scope

This specification applies to HQ0402H-01 series of thin film radio frequency inductor.

2. Product Description and Identification (Part Number)

- 1) Description
HQ0402H-01 series of thin film radio frequency inductor.
- 2) Product Identification (Part Number)

HQ
①
0402
②
H
③
XXX
④
□
⑤
◎
⑥
01
⑦

① Type	
HQ	High Q Ceramic Chip Inductor

② External Dimensions (L X W) (mm)	
0402 [01005]	0.4 X 0.2

③ Applications and Characteristics Code	
H	High Q

④ Nominal Inductance	
Example	Nominal Value
3N9	3.9nH
10N	10nH

⑤ Inductance Tolerance	
B、C、S	±0.1、±0.2、±0.3nH
G、H、J	±2%、±3%、±5%

⑥ Packing	
T	Tape Carrier Package

⑦ Serial Code	
01	

3. Electrical Characteristics

Please refer to **Appendix A** (Page10-13).

- 1) Operating and storage temperature range (individual chip without packing): -55°C~ +125°C,
- 2) Storage temperature range (packaging conditions): -10°C~+40°C and RH 70% (Max.)

4. Shape and Dimensions

- 1) Dimensions and recommended PCB pattern for reflow soldering: See **Fig.4-1**, **Fig.4-2** and **Table 4-1**.
- 2) Structure: See **Fig. 4-3** and **Fig. 4-4**.

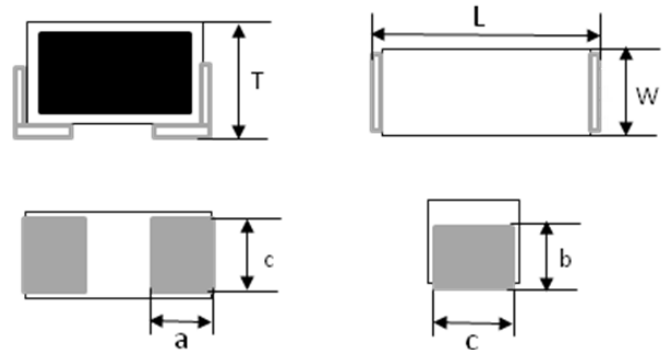
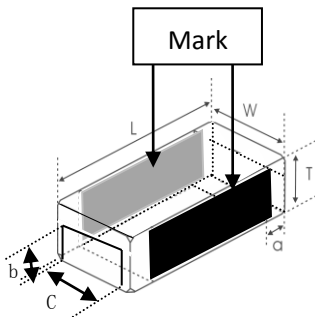

Fig. 4-1

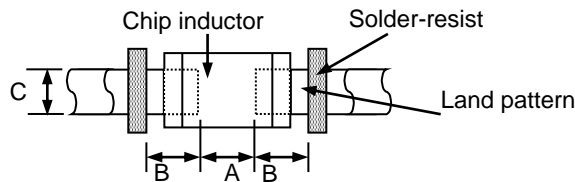
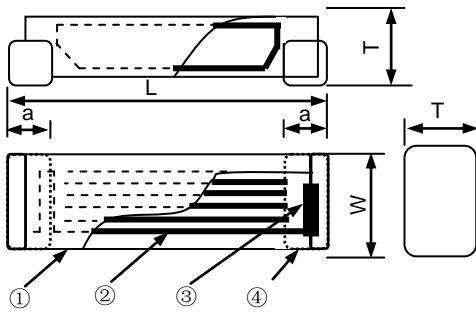

Fig. 4-2

[Table4-1]

Unit: mm[inch]

Type	L	W	T	a	b	c	A	B	C
0402	0.4±0.02	0.2±0.02	0.2±0.02	0.14±0.03	0.14±0.03	0.17±0.03	0.15~0.19	0.18~0.22	0.18~0.22
[01005]	[.016±.0008]	[.008±.0008]	[.008±.0008]	[.005±.0010]	[.005±.0010]	[.006±.0010]			



[Fig 4-3]

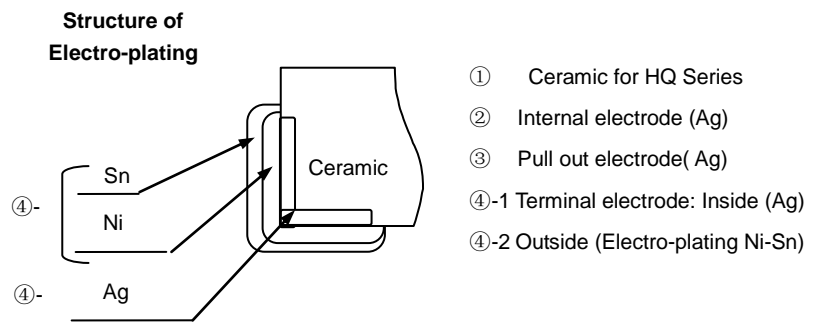

[Fig 4-4]

3) Material Information: See **Table 4-2**

Code	Part Name	Material Name
①	Ceramic Body	Ceramic Powder
②	Inner Coils	Silver Paste
③	Pull-out Electrode (Ag)	Silver Paste
④-1	Terminal Electrode: Inside Ag	Silver Paste
④-2	Electro-Plating: Ni/Sn plating	Plating Chemicals

4) Soldering Notice: The surface with the mark should be on the two beside when soldering

5. Test and Measurement Procedures

5.1 Test Conditions

5.1.1 Unless otherwise specified, the standard atmospheric conditions for measurement/test as:

- Ambient Temperature: $20 \pm 15^\circ\text{C}$
- Relative Humidity: $65 \pm 20\%$
- Air Pressure: 86 KPa to 106 KPa

5.1.2 If any doubt on the results, measurements/tests should be made within the following limits:

- Ambient Temperature: $20 \pm 2^\circ\text{C}$
- Relative Humidity: $65 \pm 5\%$
- Air Pressure: 86KPa to 106 KPa

5.2 Visual Examination

- Inspection Equipment: 60 X magnifier

5.3 Electrical Test

5.3.1 DC Resistance (DCR)

- Refer to **Appendix A**.
- Test equipment (Analyzer): High Accuracy Milliohmmeter-HP4338B or equivalent.

5.3.2 Inductance (L)

- Refer to **Appendix A**.
- Test equipment: High Accuracy RF Impedance /Material Analyzer-E4991A+16196D or equivalent.
- Test signal: -20dBm or 50mV
- Test frequency refers to Appendix A.
- Short bar residual inductance=0.11nH

5.3.3 Q Factor (Q)

- Refer to **Appendix A**.
- Test equipment: High Accuracy RF Impedance /Material Analyzer-E4991A+16196D or equivalent.
- Test signal: -20dBm or 50mV
- Test frequency refers to Appendix A.

5.3.4 Self-Resonant Frequency (SRF)

- Refer to **Appendix A**.
- Test equipment: Agilent 8719ES or equivalent.
- Test signal: -20 dBm or 50 mV

5.3.5 Rated Current

- Refer to **Appendix A**.
- Test equipment (see **Fig. 5.3.5-1**): Electric Power, Electric current meter, Thermometer.
- Measurement method (see **Fig. 5.3.5-1**):
 - Set test current to be 0 mA.
 - Measure initial temperature of chip surface.
 - Gradually increase voltage and measure chip temperature for corresponding current.
- Definition of Rated Current(I_r): I_r is direct electric current as chip surface temperature rose just 20°C against chip initial surface temperature(T_a) (see **Fig. 5.3.5-2**).

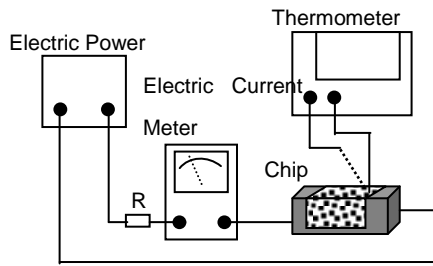

Fig. 5.3.5-1

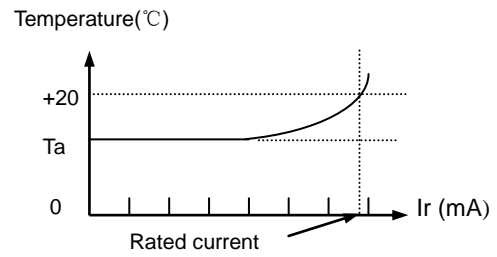
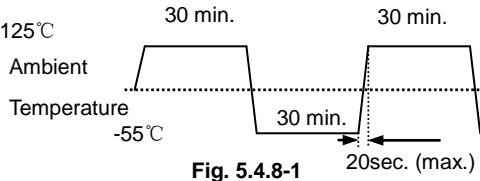

Fig. 5.3.5-2

5.4 Reliability Test

Items	Requirements	Test Methods and Remarks								
5.4.1 Terminal Strength	<p>No removal or split of the termination or other defects shall occur.</p> <p>Fig.5.4.1-1</p>	<ol style="list-style-type: none"> Solder the inductor to the testing jig (glass epoxy board shown in Fig. 5.4.1-1) using leadfree solder. Then apply a force in the direction of the arrow 1N force for HQ0402H-01 series Keep time: 10±1s Speed: 1.0mm/s 								
5.4.2 Resistance to Flexure	<p>No visible mechanical damage.</p> <p>Unit: mm [inch]</p> <table border="1" data-bbox="277 927 708 1016"> <thead> <tr> <th>Type</th> <th>a</th> <th>b</th> <th>c</th> </tr> </thead> <tbody> <tr> <td>0402[01005]</td> <td>0.18</td> <td>0.8</td> <td>0.2</td> </tr> </tbody> </table> <p>Fig. 5.4.2-1</p>	Type	a	b	c	0402[01005]	0.18	0.8	0.2	<ol style="list-style-type: none"> Solder the inductor to the test jig (glass epoxy board shown in Fig. 5.4.2-1) Using a leadfree solder. Then apply a force in the direction shown Fig. 5.4.2-2. Flexure: 2mm. Pressurizing Speed: 0.5mm/sec. Keep time: 30 sec. <p>Fig. 5.4.2-2</p>
Type	a	b	c							
0402[01005]	0.18	0.8	0.2							
5.4.3 Vibration	<ol style="list-style-type: none"> No visible mechanical damage. Inductance change: Within ±10%. Q factor change: Within ±20%. <p>Fig. 5.4.3-1</p>	<ol style="list-style-type: none"> Solder the inductor to the testing jig (glass epoxy board shown in Fig. 5.4.3-1) using leadfree solder. The inductor shall be subjected to a simple harmonic motion having total amplitude of 1.5mm, the frequency being varied uniformly between the approximate limits of 10 and 55 Hz. The frequency range from 10 to 55 Hz and return to 10 Hz shall be traversed in approximately 1 minute. This motion shall be applied for a period of 2 hours in each 3 mutually perpendicular directions (total of 6 hours). 								
5.4.4 Dropping	<ol style="list-style-type: none"> No visible mechanical damage. Inductance change: Within ±10%. Q factor change: Within ±20%. 	<p>Drop chip inductor 10 times on a concrete floor from a height of 100 cm.</p>								
5.4.5 Temperature	<p>Inductance change should be within ±10% of initial value measuring at 20°C.</p>	<p>Temperature range: HQ0402H-01: -55°C to +125°C, Reference temperature: +20°C</p>								
5.4.6 Solderability	<ol style="list-style-type: none"> No visible mechanical damage. Wetting shall exceed 95% coverage. 	<ol style="list-style-type: none"> Solder temperature: 240±2°C Duration: 3 sec. Solder: Sn/3.0Ag/0.5Cu. Flux: 25% Resin and 75% ethanol in weight. 								
5.4.7 Resistance to Soldering Heat	<ol style="list-style-type: none"> No visible mechanical damage. Wetting shall exceed 75% coverage. Inductance change: Within ±10%. Q factor change: Within ±20%. 	<ol style="list-style-type: none"> Solder temperature: 260±3°C Duration: 5 sec. Solder: Sn/3.0Ag/0.5Cu. Flux: 25% Resin and 75% ethanol in weight. The chip shall be stabilized at normal condition for 1~2 hours before measuring. 								

<p>5.4.8 Thermal Shock</p>	<p>① No mechanical damage. ② Inductance change: Within $\pm 10\%$. ③ Q factor change: Within $\pm 20\%$.</p>  <p>Fig. 5.4.8-1</p>	<p>① Temperature, Time: (See Fig. 5.4.8-1) HQ0402H-01: -55°C for 30 ± 3 min \rightarrow 125°C for 30 ± 3 min, ② Transforming interval: Max. 20 sec. ③ Tested cycle: 100 cycles. ④ The chip shall be stabilized at normal condition for 1~2 hours before measuring.</p>
<p>5.4.9 Resistance to Low Temperature</p>	<p>① No mechanical damage. ② Inductance change: Within $\pm 10\%$. ③ Q factor change: Within $\pm 20\%$.</p>	<p>① Temperature: $-55\pm 2^{\circ}\text{C}$, ② Duration: 1000^{+24} hours. ③ The chip shall be stabilized at normal condition for 1~2 hours before measuring.</p>
<p>5.4.10 Resistance to High Temperature</p>	<p>① No mechanical damage. ② Inductance change: Within $\pm 10\%$. ③ Q factor change: Within $\pm 20\%$.</p>	<p>① Temperature: $125\pm 2^{\circ}\text{C}$, ② Duration: 1000^{+24} hours. ③ The chip shall be stabilized at normal condition for 1~2 hours before measuring.</p>
<p>5.4.11 Damp Heat (Steady States)</p>	<p>① No visible mechanical damage. ② Inductance change: Within $\pm 10\%$. ③ Q factor change: Within $\pm 20\%$.</p>	<p>① Temperature: $60\pm 2^{\circ}\text{C}$ ② Humidity: 90% to 95% RH. ③ Duration: 1000^{+24} hours. ④ The chip shall be stabilized at normal condition for 1~2 hours before measuring.</p>
<p>5.4.12 Loading Under Damp Heat</p>	<p>① No visible mechanical damage. ② Inductance change: Within $\pm 10\%$. ③ Q factor change: Within $\pm 20\%$.</p>	<p>① Temperature: $60\pm 2^{\circ}\text{C}$ ② Humidity: 90% to 95% RH. ③ Duration: 1000^{+24} hours. ④ Applied current: Rated current. ⑤ The chip shall be stabilized at normal condition for 1~2 hours before measuring.</p>
<p>5.4.13 Loading at High Temperature (Life Test)</p>	<p>① No visible mechanical damage. ② Inductance change: Within $\pm 10\%$. ③ Q factor change: Within $\pm 20\%$.</p>	<p>① Temperature: $125\pm 2^{\circ}\text{C}$, ② Duration: 1000^{+24} hours. ③ Applied current: Rated current. ④ The chip shall be stabilized at normal condition for 1~2 hours before measuring.</p>

6. Packaging and Storage

6.1 Packaging

Tape Carrier Packaging:

Packaging code: T

- a. Tape carrier packaging are specified in attached figure Fig.6.1-1~3
- b. Tape carrier packaging quantity please see the following table:

Type	0402[01005]
Thickness (mm)	0.2 \pm 0.02
Tape	Paper Tape
Quantity	20K

(1) Taping Drawings (Unit: mm)

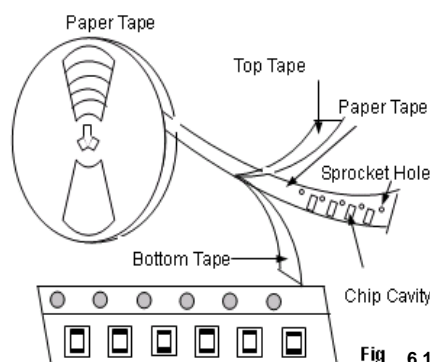

Remark: The sprocket holes are to the right as the tape is pulled toward the user.

(2) Taping Dimensions (Unit: mm)

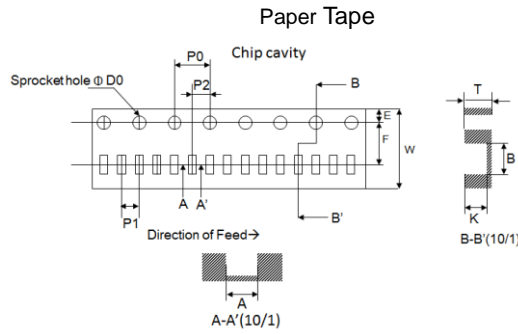

Fig. 6.1-2

Table 6.1-1

Unit:mm

Type	A	B	K	P0	P1	P2	D0	T max	E	F	W
0402	0.24 ± 0.02	0.44 ± 0.02	0.24 ± 0.02	4.0 ± 0.1	2.0 ± 0.05	2.0 ± 0.05	1.5 ± 0.1	0.35	1.75 ± 0.1	3.5 ± 0.05	8.0 ± 0.3

(2) Reel Dimensions (Unit: mm)

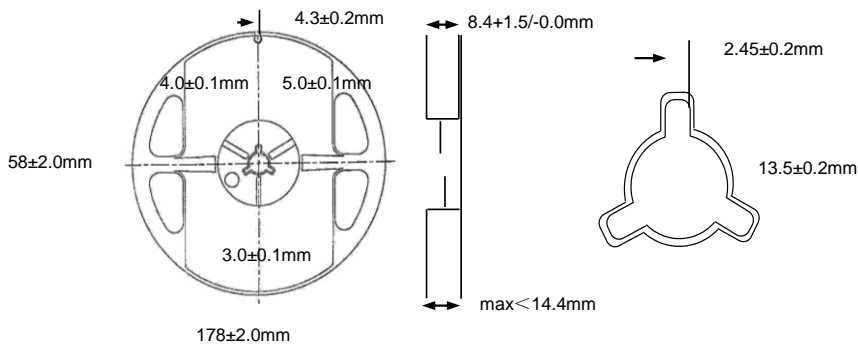

Fig. 6.1-3

6.2 Storage

- a. The solderability of the external electrode may be deteriorated if packages are stored where they are exposed to high humidity. Package must be stored at 40°C or less and 70% RH or less.
- b. The solderability of the external electrode may be deteriorated if packages are stored where they are exposed to dust of harmful gas (e.g. HCl, sulfurous gas of H_2S).
- c. Packaging material may be deformed if package are stored where they are exposed to heat of direct sunlight.
- d. Solderability specified in **Clause 5.4.6** shall be guaranteed for 12 months from the date of delivery on condition that they are stored at the environment specified in **Clause 3**. For those parts, which passed more than 12 months shall be checked solder-ability before use.

7. Recommended Soldering Technologies

7.1 Reflow Profile

- △ Preheat condition: $150 \sim 200^\circ\text{C}/60 \sim 120$ sec.
- △ Allowed time above 217°C : $60 \sim 90$ sec.
- △ Max temp: 260°C
- △ Max time at max temp: 10sec.
- △ Solder paste: Sn/3.0Ag/0.5Cu
- △ Allowed Reflow time: 2x max

[Note: The reflow profile in the above table is only for qualification and is not meant to specify board assembly profiles. Actual board assembly profiles must be based on the customer's specific board design, solder paste and process, and should not exceed the parameters as the Reflow profile shows.]

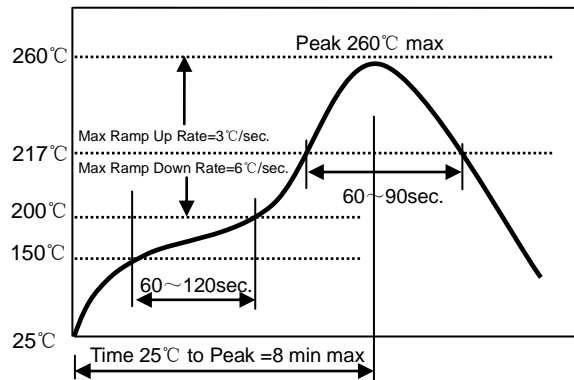

7.2 Iron Soldering Profile

- △ Iron soldering power: Max. 30W
- △ Pre-heating: $150^\circ\text{C}/60$ sec.
- △ Soldering Tip temperature: 350°C Max.
- △ Soldering time: 3sec. Max.
- △ Solder paste: Sn/3.0Ag/0.5Cu
- △ Max.1 times for iron soldering

[Note: Take care not to apply the tip of the soldering iron to the terminal electrodes.]

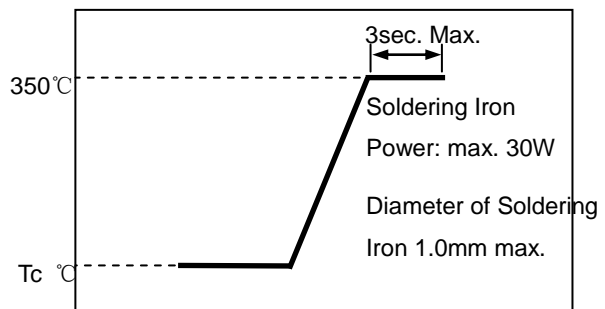

Appendix A: Electrical Characteristics (HQ0402H-01 Series of Inductors)

HQ0402H-01 Series of Inductor

Part Number 型号	Inductance 电感量	Min. Quality Factor 品质因子	L, Q Test Freq. L/Q 测试频率	Typical Q @ Freq. (GHz)					Min. Self-resonant Frequency 自谐振频率	Max. DC Resistance 直流电阻	Max. Rated Current 额定电流	Thickness 厚度
				0.5	0.8	1.8	2	2.4				
Units	nH	-	MHz	-					MHz	Ω	mA	mm [inch]
Symbol	L	Q	Freq	Q					S.R.F	DCR	Ir	T
HQ0402H0N2□T01	0.2	-	500	-	-	-	-	-	16600	0.1	990	0.2±0.02 [.008±0008]
HQ0402H0N3□T01	0.3	-	500	-	-	-	-	-	16600	0.1	990	
HQ0402H0N4□T01	0.4	-	500	-	-	-	-	-	16600	0.1	990	
HQ0402H0N5□T01	0.5	11	500	15	18	33	35	40	16600	0.1	730	
HQ0402H0N6□T01	0.6	11	500	15	17	32	34	40	16600	0.1	730	
HQ0402H0N7□T01	0.7	11	500	15	18	34	36	41	16600	0.1	730	
HQ0402H0N8□T01	0.8	11	500	14	18	32	35	41	16600	0.15	630	
HQ0402H0N9□T01	0.9	11	500	15	18	32	34	38	16600	0.15	580	
HQ0402H1N0□T01	1	11	500	14	19	32	35	42	16600	0.15	580	
HQ0402H1N1□T01	1.1	11	500	15	19	31	33	36	16600	0.15	580	
HQ0402H1N2□T01	1.2	11	500	15	20	32	34	38	16600	0.2	550	
HQ0402H1N3□T01	1.3	11	500	14	18	29	31	34	16000	0.2	400	
HQ0402H1N4□T01	1.4	11	500	15	19	30	32	38	15000	0.2	400	
HQ0402H1N5□T01	1.5	11	500	15	19	31	32	33	15000	0.2	400	
HQ0402H1N6□T01	1.6	11	500	14	18	30	31	35	15000	0.3	390	
HQ0402H1N7□T01	1.7	11	500	14	18	30	32	35	15000	0.3	380	
HQ0402H1N8□T01	1.8	11	500	14	19	30	32	34	15000	0.3	380	
HQ0402H1N9□T01	1.9	11	500	14	18	30	32	35	13000	0.3	380	
HQ0402H2N0□T01	2	11	500	15	19	31	33	35	13000	0.3	380	
HQ0402H2N1□T01	2.1	11	500	14	18	29	32	35	13000	0.3	380	
HQ0402H2N2□T01	2.2	11	500	15	20	32	34	34	13000	0.3	380	
HQ0402H2N3□T01	2.3	11	500	15	19	30	32	38	13000	0.4	370	
HQ0402H2N4□T01	2.4	11	500	15	20	31	33	35	13000	0.4	370	
HQ0402H2N5□T01	2.5	11	500	14	18	29	31	35	11500	0.4	370	
HQ0402H2N6□T01	2.6	11	500	14	18	30	32	35	11500	0.4	370	
HQ0402H2N7□T01	2.7	11	500	14	19	30	32	34	11500	0.4	370	
HQ0402H2N8□T01	2.8	11	500	14	18	29	31	35	10000	0.4	360	
HQ0402H2N9□T01	2.9	11	500	14	18	28	31	35	10000	0.45	360	
HQ0402H3N0□T01	3	11	500	14	17	28	30	34	10000	0.45	360	
HQ0402H3N1□T01	3.1	11	500	14	18	28	31	35	10000	0.9	290	
HQ0402H3N2□T01	3.2	11	500	14	18	31	32	34	10000	0.9	290	
HQ0402H3N3□T01	3.3	11	500	14	18	30	31	33	10000	0.9	290	
HQ0402H3N4□T01	3.4	11	500	14	17	27	29	33	9700	1	280	
HQ0402H3N5□T01	3.5	11	500	14	17	28	30	32	9700	1	280	
HQ0402H3N6□T01	3.6	11	500	14	17	27	29	31	9700	1	280	
HQ0402H3N7□T01	3.7	11	500	13	17	27	29	33	9700	1	270	
HQ0402H3N8□T01	3.8	11	500	14	17	27	29	32	9700	1	270	
HQ0402H3N9□T01	3.9	11	500	14	17	25	26	30	9700	1	270	
HQ0402H4N0□T01	4	11	500	14	16	26	28	30	9000	1	270	
HQ0402H4N1□T01	4.1	11	500	14	17	26	28	31	9000	1	270	
HQ0402H4N2□T01	4.2	11	500	14	17	27	29	31	9000	1	270	

(Continued)

Part Number 型号	Inductance 电感量	Min. Quality Factor 品质因子	L, Q Test Freq. L/Q 测试频 率	Typical Q @ Freq. (GHz)					Min. Self- resonant Frequency 自谐振频 率	Max. DC Resistance 直流电阻	Max. Rated Current 额定电流	Thickness 厚度
				0.5	0.8	1.8	2	2.4				
Units	nH	-	MHz	-					MHz	Ω	mA	mm [inch]
Symbol	L	Q	Freq	Q					S.R.F	DCR	I _r	T
HQ0402H4N3□T01	4.3	11	500	14	17	26	28	31	9000	1	270	0.2±0.02 [.008±0008]
HQ0402H4N7□T01	4.7	11	500	14	17	25	27	30	8500	1	270	
HQ0402H5N1□T01	5.1	11	500	14	17	26	28	31	7800	1.2	250	
HQ0402H5N6□T01	5.6	11	500	15	18	30	31	33	7800	1.3	230	
HQ0402H6N2□T01	6.2	11	500	15	18	30	31	32	7200	1.3	220	
HQ0402H6N8□T01	6.8	11	500	15	19	29	31	33	6600	1.4	210	
HQ0402H7N5□T01	7.5	11	500	14	19	28	31	33	6600	1.5	200	
HQ0402H8N2□T01	8.2	11	500	15	20	29	31	33	6600	1.6	190	
HQ0402H9N1□T01	9.1	11	500	15	19	28	31	32	5900	1.7	170	
HQ0402H10N□T01	10	11	500	14	18	26	29	31	5900	1.7	170	
HQ0402H11N□T01	11	11	500	14	17	25	26	28	3500	1.9	140	
HQ0402H12N□T01	12	11	500	14	17	25	26	28	3500	2.1	140	
HQ0402H13N□T01	13	10	500	13	16	23	24	24	3000	2.1	140	
HQ0402H15N□T01	15	10	500	13	16	23	24	24	3000	2.3	140	
HQ0402H16N□T01	16	10	500	12	15	21	21	21	2500	2.5	140	
HQ0402H18N□T01	18	9	500	10	12	17	17	16	2500	2.5	140	
HQ0402H20N□T01	20	9	500	10	11	16	16	15	2700	2.9	140	
HQ0402H22N□T01	22	9	500	10	11	15	15	13	2300	3.2	120	
HQ0402H24N□T01	24	9	500	10	11	15	16	13	2200	3.2	120	
HQ0402H27N□T01	27	9	500	10	12	16	17	13	2000	3.5	120	
HQ0402H30N□T01	30	6	500	10	12	13	12	10	1800	3.6	120	
HQ0402H33N□T01	33	6	300	10	12	12	11	8	1800	3.8	120	

Note: □: Please specify the inductance tolerance. For $L \leq 4.2\text{nH}$, choose $B = \pm 0.1\text{nH}$, $C = \pm 0.2\text{nH}$ or $S = \pm 0.3\text{nH}$; For $4.2\text{nH} < L < 5.6\text{nH}$, choose, $H = \pm 3\%$, $J = \pm 5\%$. or $S = \pm 0.3\text{nH}$; For $L \geq 5.6\text{nH}$, choose, $H = \pm 3\%$, $J = \pm 5\%$

TYPICAL ELECTRICAL CHARACTERISTICS

Inductance-Frequency Characteristics(Typ.)

Q-Frequency Characteristics(Typ.)

HQ0402H1N0BT01

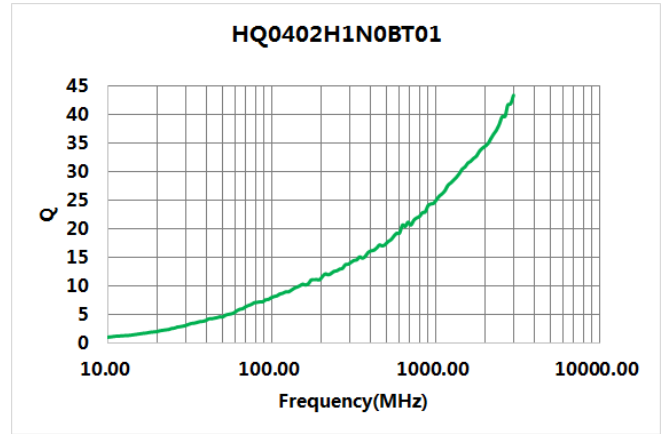
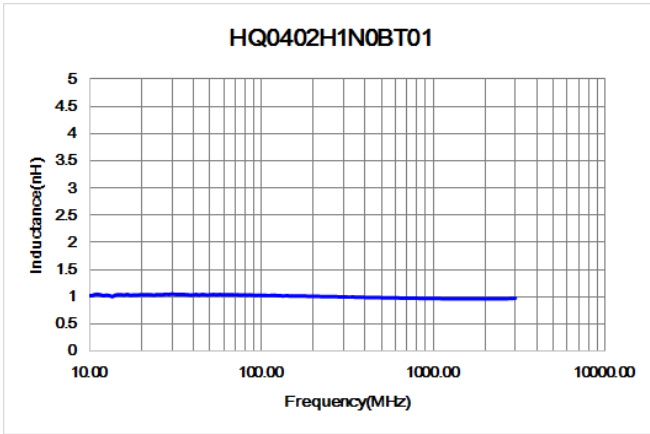

HQ0402H2N4BT01

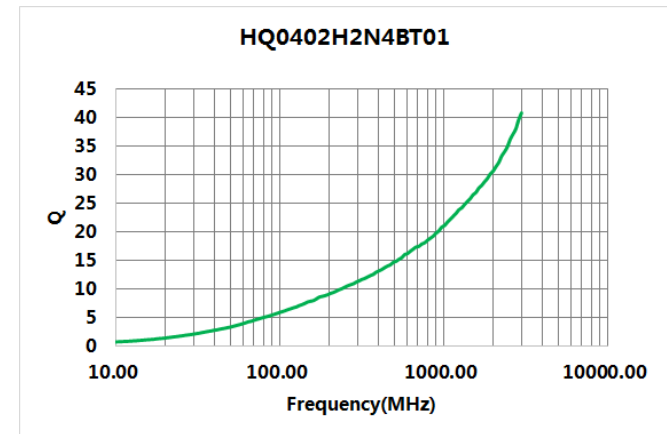
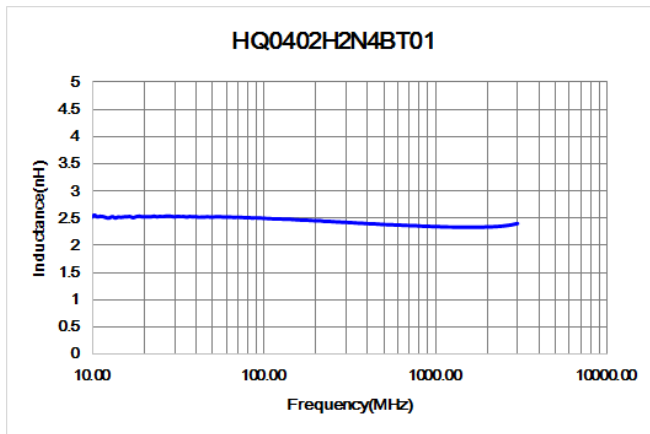

HQ0402H5N6HT01

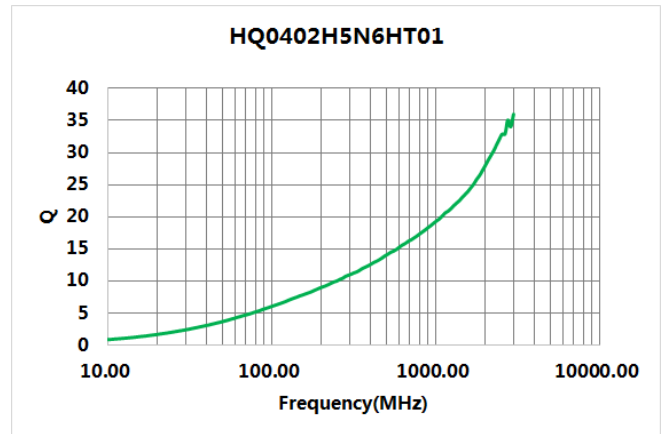
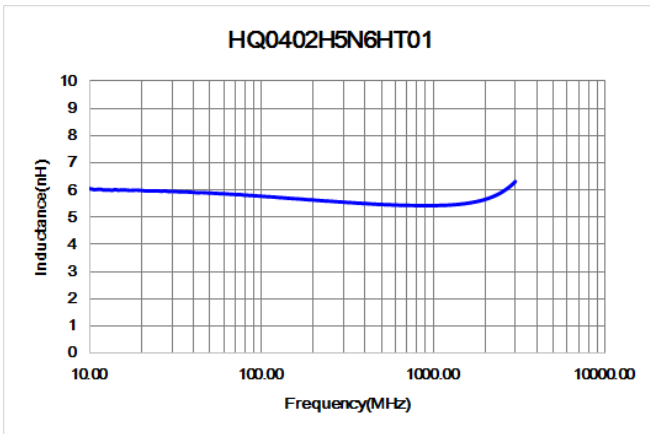

HQ0402H10NHT01

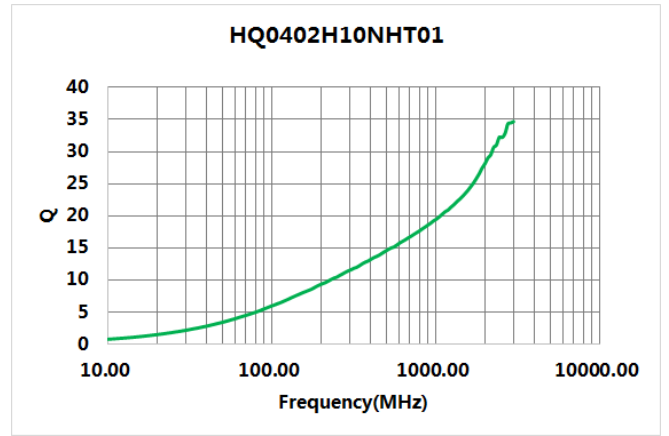
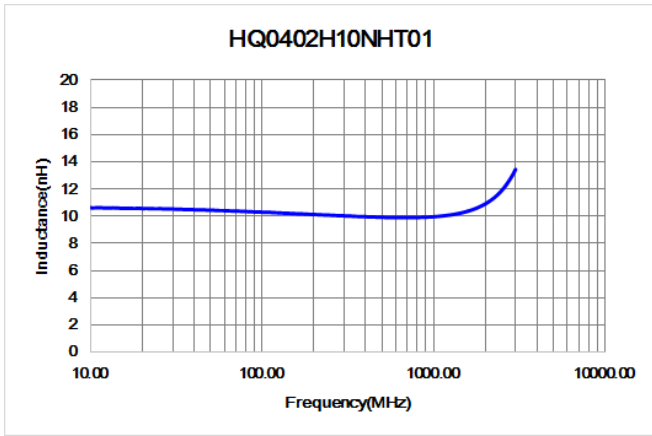

HQ0402H20NHT01

